



For long-life performance and peace of mind, trust the name chosen by the world's five largest heavy-duty engine builders...

Mobil Delvac

Imperial Oil
237 Fourth Avenue SW
Calgary, Alberta T2P 3M9

www.imperialoil.ca

© 2009 Exxon Mobil Corporation

Imperial Oil is a trademark of Imperial Oil Limited.
Imperial Oil, licensee.

Mobil and Delvac are trademarks of Exxon Mobil Corporation or one of its subsidiaries.
Imperial Oil, licensee.

Printed in Canada 06/2009 ILXXXX

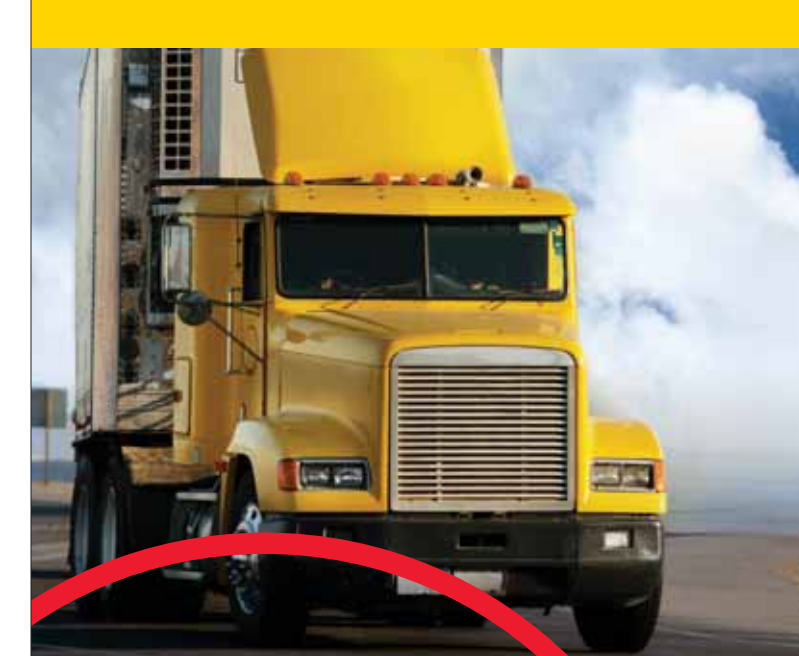

- ▶ Long Life
- ▶ Performance
- ▶ Peace of Mind



From Coast to Coast

CANADA'S TRUCKING PROFESSIONALS
TRUST MOBIL DELVAC TECHNOLOGY

from Bumper to Bumper

Imperial Oil Lubricants & Specialties

Mobil Delvac

Long-life Performance for your Engine and Powertrain

► Mobil Delvac 1 ESP 0W-40 Synthetic Engine Oil

- State-of-the-art lubricant technology delivers exceptional year-round performance
- Formulated for reliable cold-weather starts in sub-zero temperatures and safe cold-morning warm-ups with less risk of metal-to-metal contact
- Exceptional protection against engine wear, even under high-load conditions
- API-licensed CJ-4 for low-emission engines, including those with Diesel Particulate Filters (DPFs)

► Mobil Delvac 1 ESP 5W-40 Synthetic Engine Oil

- Promotes increased engine life, with the potential for extended oil drains and greater fuel economy
- Exceptional performance in low-emission engines, including those with Diesel Particulate Filters (DPFs)
- Superb cold-weather performance

► Mobil Delvac 1300 Super 10W-30 and 15W-40

- Extra-high performance formulation promotes extended engine life, even under severe conditions
- Meets or exceeds API CJ-4 and OEM performance requirements for late-model low-emission engines
- Recommended for a wide range of heavy-duty applications, on highway and off

► Mobil Delvac Synthetic Transmission Fluid 50

- Approved by major OEMs for extended warranties
- Reduced wear and longer gear life over conventional automotive transmission fluids through outstanding load carrying, antiwear and EP performance
- Excellent viscosity control for improved fuel economy and long equipment life

► Mobil Delvac Synthetic ATF

- Synthetic formulation includes SuperSyn, for peak performance even in severe operating conditions
- Outstanding gear shifting and power transfer
- Excellent performance at sub-zero temperatures

► Mobil Delvac Synthetic Gear Oil 75W-90 and 80W-140

- Approved by major OEMs for extended warranties
- Extended gear life due to high film strength and improved low-temperature properties
- Improved fuel efficiency over conventional automotive gear lubricants

Bumper-to-bumper recommendations for your truck

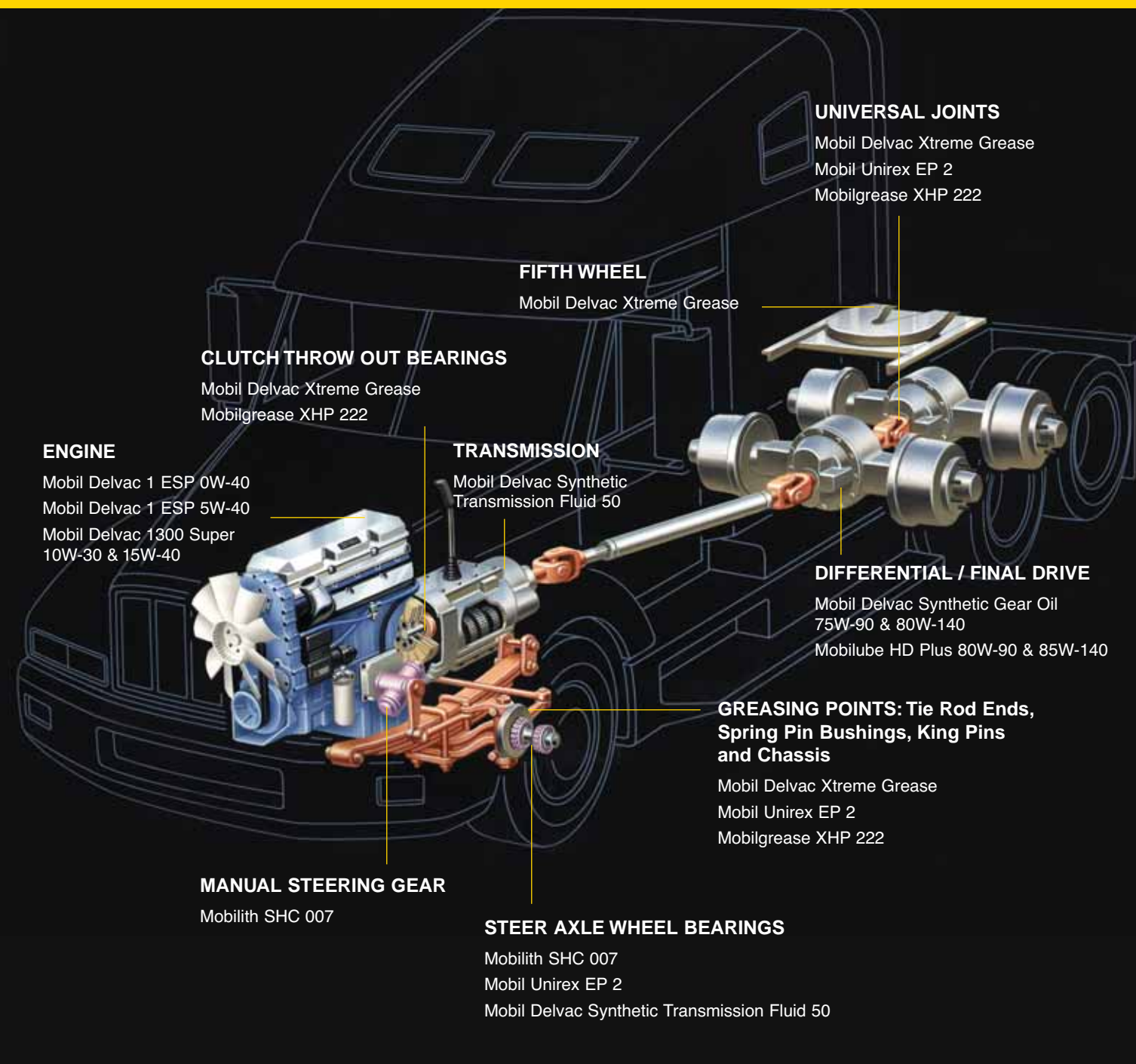

Outstanding Year-round Protection for Bearings and Bushings

► Mobilith SHC 007

- Synthetic basestock fluids deliver excellent low-temperature pumpability and very low starting and running torque
- Lithium complex thickeners provide excellent adhesion, structural stability and resistance to water
- Extended service intervals with regular fill level and maintenance inspections

► Mobil Unirex EP 2

- Exceptional resistance to water washout and sprayoff; water resistance also helps resist ice formation in bearings on cold overnight stops
- Excellent performance at high and low temperatures; dependable low-temperature torque keeps bearings rolling freely, even on severe cold-morning start-ups
- Outstanding cohesive qualities hold the grease together for long-term protection
- Carries National Lubricating Grease Institute (NLGI) designation as a GC-LB grease
- Powerful resistance to corrosion
- Ideal for a wide range of mobile equipment, including Canadian road-transport vehicles in severe service

► Mobil Delvac Xtreme Grease

- Excellent resistance to wear and water intrusion
- Excellent stay-in-place properties at high temperatures and under high loads
- High performance with up to 30,000-mile service intervals

► Mobilgrease XHP 222

- Ideal for general chassis lubrication
- Excellent rust and corrosion protection
- Extended life in high-temperature service

Original Equipment Manufacturer (OEM) approvals on these Mobil lubricants

All of the Mobil products in this folder meet industry or major OEM requirements.

For more information, please contact your Imperial Oil sales professional or call Imperial Oil Technical Services at **1 800 268-3183**.